

# Installation Manual

Nonlinear Editing System  
Hard Disk Box

AY-EB500



**Panasonic**®

Before attempting to connect or operate this product, please read these instructions completely

# CONTENTS

PREFACE .....	1
PRECAUTIONS .....	1
MAJOR OPERATING CONTROLS AND THEIR FUNCTION .....	2
INITIAL SETTING .....	3
INSTALLATION .....	4
CONNECTION .....	8
SPECIFICATIONS .....	9
STANDARD ACCESSORIES .....	9

	<b>CAUTION</b> RISK OF ELECTRIC SHOCK DO NOT OPEN	
<p><b>CAUTION:</b> TO REDUCE THE RISK OF ELECTRIC SHOCK, DO NOT REMOVE COVER (OR BACK). NO USER SERVICEABLE PARTS INSIDE. REFER SERVICING TO QUALIFIED SERVICE PERSONNEL.</p>		

For U.S.A

**Warning:**

This equipment generates and uses radio frequency energy and if not installed and used properly, i.e., in strict accordance with the instruction manual, may cause harmful interference to radio communications. It has been tested and found to comply with the limits for a Class A computing device pursuant to Subpart J of Part 15 of FCC Rules, which are designed to provide reasonable protection against such interference when operated in a commercial environment.

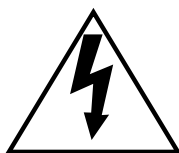

SA 1965

The lightning flash with arrowhead symbol, within an equilateral triangle, is intended to alert the user to the presence of uninsulated "dangerous voltage" within the product's enclosure that may be of sufficient magnitude to constitute a risk of electric shock to persons.



SA 1966

The exclamation point within an equilateral triangle is intended to alert the user to the presence of important operating and maintenance (servicing) instructions in the literature accompanying the appliance.

The serial number of this product may be found on the bottom of the unit.  
You should note the serial number of this unit in the space provided and retain this book as a permanent record of your purchase to aid identification in the event of theft.

Model No. AY-EB500

Serial No. \_\_\_\_\_

**WARNING:**

TO PREVENT FIRE OR SHOCK HAZARD, DO NOT EXPOSE THIS APPLIANCE TO RAIN OR MOISTURE.

## PREFACE

The AY-EB500 Nonlinear Editing System Hard Disk Box is especially designed for use with the Nonlinear Editing System.

The Hard Disk Box accepts and supplies power to up to two 3.5" HDD Units. It is provided with built-in SCSI ports (2 ports x 2) conforming to the WIDE SCSI standard.

Up to five AY-EB500 Hard Disk Boxes can be connected to the Editing System using optional Panasonic SCSI cables.

## PRECAUTIONS

- All necessary procedures, with regards to the installation of this unit should be made by qualified service personnel or system installers.
- Do not attempt to disassemble the unit.  
In order to prevent electric shock, do not remove screws or covers. There are no user-serviceable parts inside.  
Do refer all servicing to qualified service personnel.
- Handle the unit with care.  
Do not abuse the unit. Avoid striking, shaking, etc. It could be damaged by improper handling or storage.
- Do not expose the unit to rain or moisture, or try to operate it in wet areas.  
Take immediate action if the unit becomes wet. Turn the power off and refer servicing to qualified service personnel. Moisture can damage the unit and also create the danger of electric shock.
- Do not use strong or abrasive detergents when cleaning the unit body.  
Use a dry cloth to clean the unit when dirty.  
In case the dirt is hard to remove, use a mild detergent and wipe gently.
- Do not operate the unit beyond its temperature, humidity or power source ratings.  
Do not use the unit in an extreme environment where high temperature or high humidity exist.  
Use the unit under conditions where temperature is within 32°F - 95°F (0°C - +35°C), and humidity is within 10% - 90%.  
The input power source is 120V AC 60Hz.

# MAJOR OPERATING CONTROLS AND THEIR FUNCTION

## FRONT PANEL

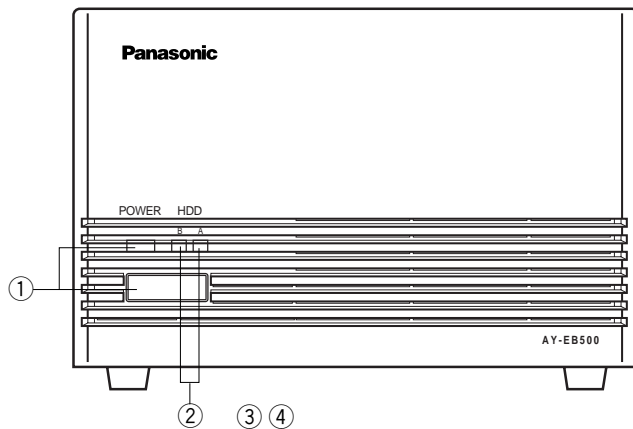

## REAR PANEL

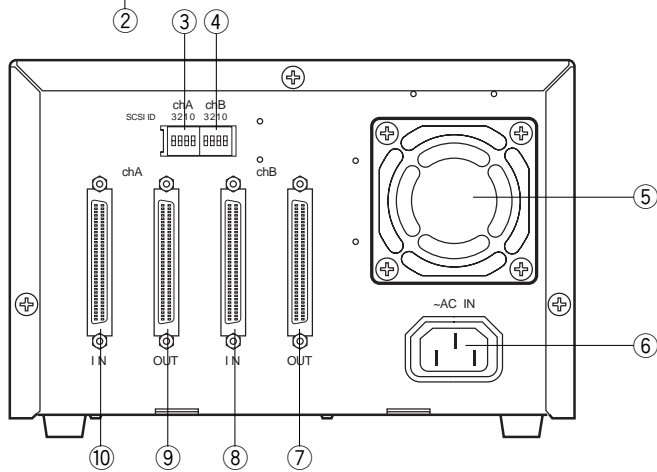

### 1. Power Button/Power Indicator (POWER)(Red)

Press this button to turn on the power. The Power Indicator lights red while the power is on.

**Caution:** Do not turn off the power during recording or playback mode.

### 2. HDD Operating Indicator (HDD)(green)

Green light indicates that the HDD is in operation.

### Caution

#### • Switching Power Off

Before switching power off, terminate all the software programs according to the procedures given in the Reference Manual supplied with the software package (AY-AS501). If power is switched off while the software (HDD) is running, the HDD may lose its data stored on it, or fail. Do not move the HDD for about 30 seconds after switching power off because the HDD motor is still running.

#### • Switching Power On

Switch power on in the order of SCSI-ID1, SCSI-ID2, SCSI-ID3, SCSI-ID4, and SCSI-ID5. Also observe the switching on sequence of the HDD box and the main unit.

**3. SCSI ID Setup Switch for Channel A (SCSI ID, chA)**

The SCSI-ID for Channel A is set with this switch. Refer to page 8 for ID Number Setting.

**4. SCSI ID Setup Switch for Channel B (SCSI ID, chB)**

The SCSI-ID for Channel B is set with this switch.

**5. Fans**

These Fans prevent temperature rise inside the unit.  
**Note:** The fans are wear items and need to be replaced periodically.

Operating Time	Operating Life
8 hours daily	6 years
12 hours daily	4 years
24 hours daily	2 years

**6. AC Inlet (~AC IN)**

Connect the provided power cord to this Inlet.

**7. SCSI Output Connector for Channel B (chB/OUT)**  
 Connect the "chB/IN" terminal of an additional HDD-BOX to this connector.

**8. SCSI Input Connector for Channel B (chB/IN)**  
 Connect the "chB/OUT" terminal of an additional HDD-BOX to this connector.  
 Used for connection with the channel B SCSI connector of the SCSI board.

**9. SCSI Output Connector for Channel A (chA/OUT)**  
 Connect the "chA/IN" terminal of an additional HDD-BOX to this connector.

**10. SCSI Input Connector for Channel A (chA/IN)**  
 Connect the "chA/OUT" terminal of an additional HDD-BOX to this connector.  
 Used for connection with the channel A SCSI connector of the SCSI board.

**INITIAL SETTING**

 **Warning**

Before connecting an HDD, pull out the power plug from the electrical outlet for safety. Failure to do so may cause electric shock.

**Cautions**

- Before starting work, carefully read the Operating Instruction Manual attached to the HDD.
- Before handling HDDs, touch the metal case of the HDD box to discharge static from the body. For added safety, wear an antistatic wrist strap.
- Keep unused HDDs on an antistatic mat. Keep the metal parts of HDDs out of contact with the metal parts of other HDDs.

Set the jumper pins before installing HDDs.

Remove all jumper pins originally set at the factory as indicated below.

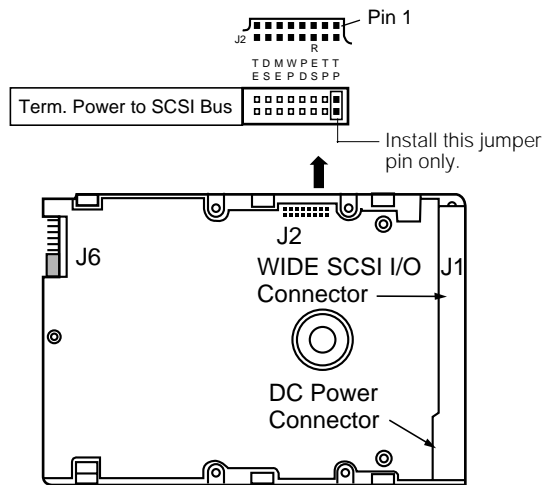

# INSTALLATION

## ■ Installation to HDD-BOX

- ① Disconnect the power cord of the HDD-BOX from the AC outlet receptacle.
- ② Remove 7 screws from the HDD-BOX.

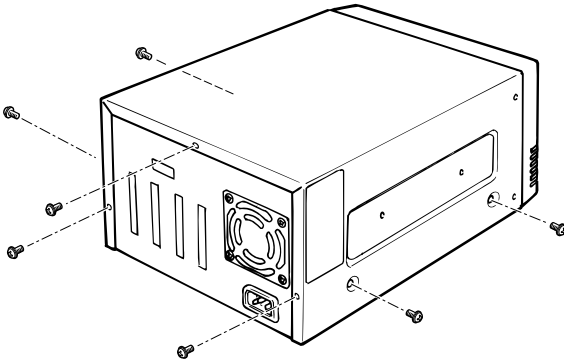

- ③ Slide the Top Cover in direction (③-1) and pull it upward (③-2).

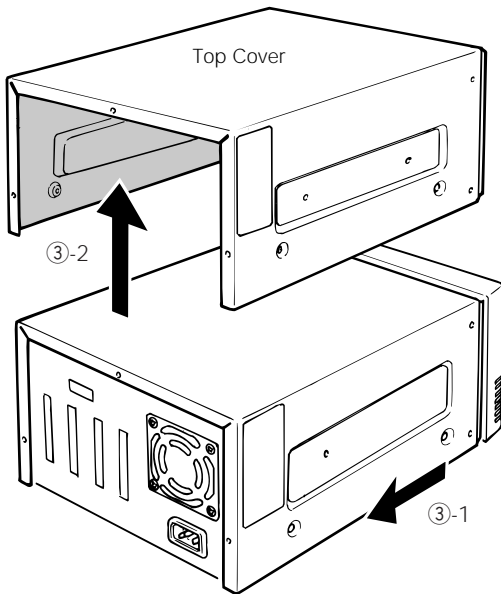

### Warning

Do not touch the power unit (indicated below ) with hands, metal or other objects. Otherwise, there is a danger of electric shock.

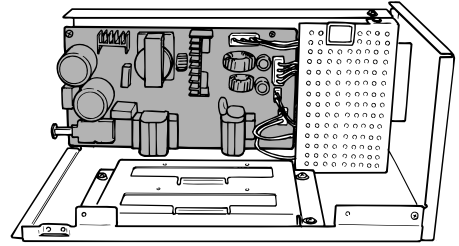

- ④ Securely fix the new HDD in the HDD Mounting Case with 4 Mounting Screws (provided).

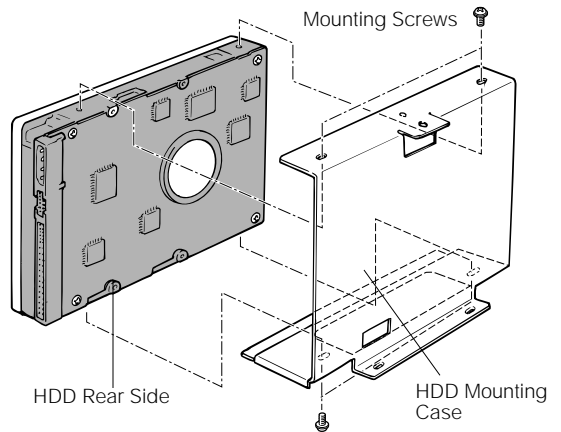

- ⑤ Fix the HDD mounted on the Mounting Case onto Mounting Angle as indicated below.

<Top View>

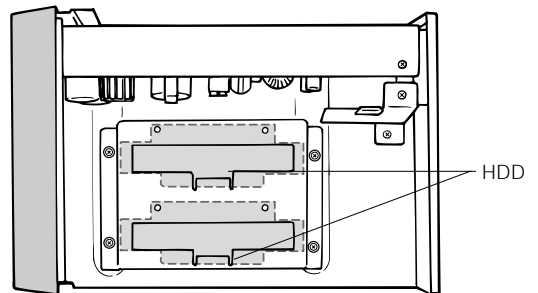

- ⑥ Fasten the HDD securely in the position shown below with two mounting screws (provided).

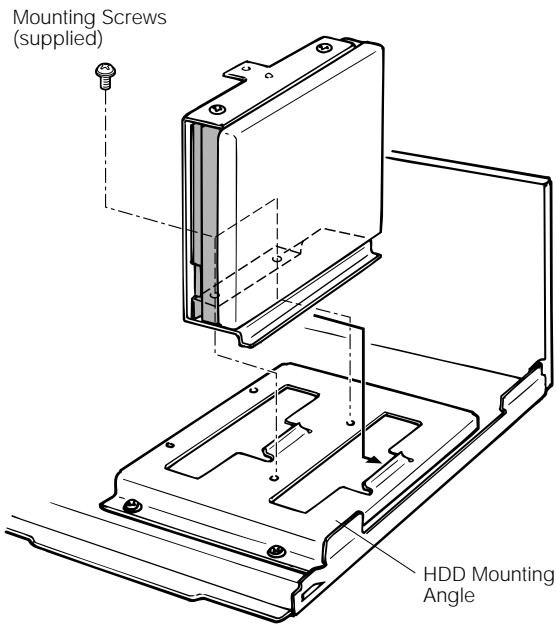

- ⑦ Fasten the Fixing Angle to the HDD Mounting Case and Chassis securely with three screws (provided).

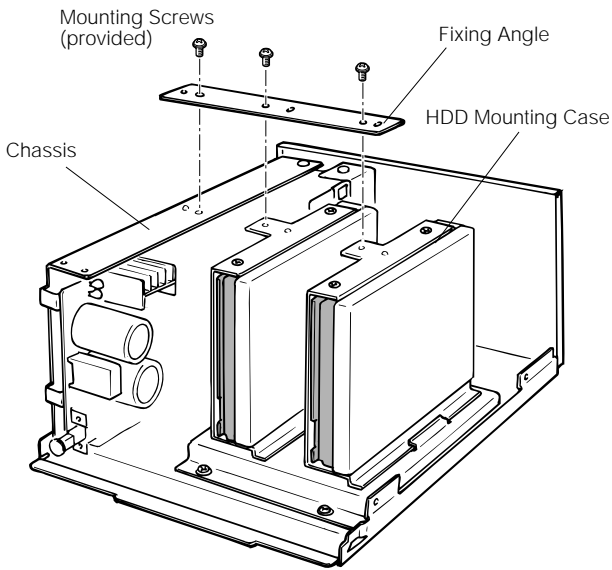

## ■ Wiring

**Note:** Securely connect cables and wires to the correct terminals referring to the drawings below. Make sure not to reverse connectors.

- ① Connect the cables from the LED PCB (③orange and ④gray) to HDD left.
- ② Connect the cables from LED PCB (①red and ②gray) to HDD right.

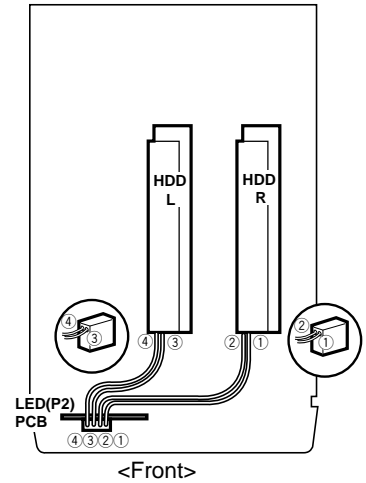

- ③ Connect the cables from the Power PCB (③orange and ④gray) to HDD left.
- ④ Connect the cables from the Power PCB (①yellow and ②gray) to HDD right.

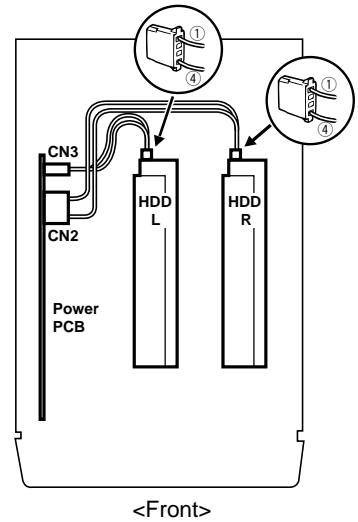

- ⑤ Connect the SCSI ID setup cable (pin ①: red) to HDD left.
- ⑥ Connect the SCSI ID setup cable (pin ①: brown) to HDD right.

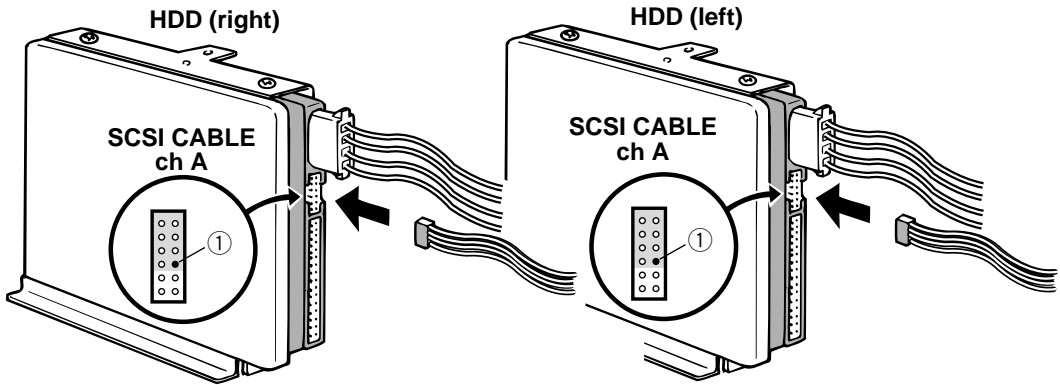

- ⑦ Connect a flat cable to HDD left.
- ⑧ Connect a flat cable to HDD right.

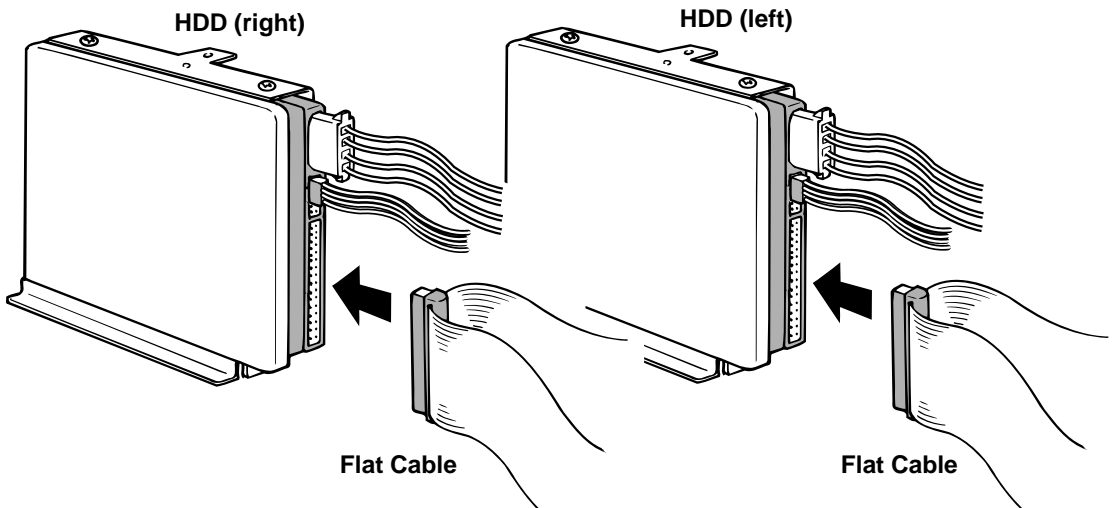



- ⑨ Lower the top cover onto the HDD-BOX (⑨-1) and slide it in direction (⑨-2).

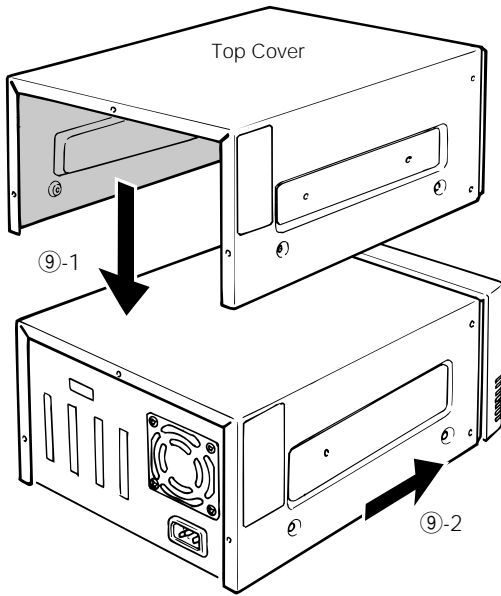

**If LED fails to light:**

Take the following steps to make sure that each cable is properly connected.

- Press the power switch off and pull out the power plug from the electrical outlet.
- Check each cable that it is properly connected.

- ⑩ Fix the top cover on the HDD-BOX with 7 screws.

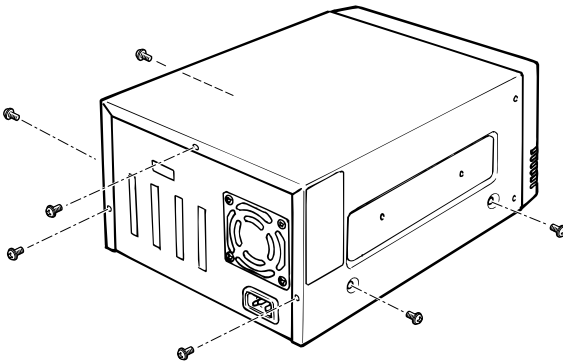

# CONNECTION

## ■ Connection of HDD-BOX and SCSI Board

### • Connection of one HDD-BOX

Connect the SCSI connector (OUT) of the SCSI board and the SCSI connector (IN) of the HDD-BOX. Make sure to match channels.

**Note:** The special SCSI cable (ACK/M-WP made by Adaptec), available as an optional part, is necessary for this connection.

### • Connection of multiple HDD-BOXes

Connect all HDD-BOXes to the SCSI board with optional SCSI cables as shown below.

**Note:** Connect them with the WIDE SCSI cables.

## ■ Terminators

### • Connection of one HDD-BOX





Insert two terminators into the chA/OUT connector and the chB/OUT connector of the HDD-BOX.

### • Connection of multiple HDD-BOXes

Insert two terminators into the chA/OUT connector and the chB/OUT connector of the HDD-BOX connected farthest from your personal computer.

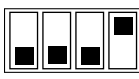
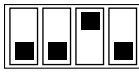
## ■ SCSI ID Setting

- Set the SCSI-ID Setup Switch located on the rear of the HDD-BOX as shown in the table below.

HDD-BOX	SCSI-ID	SCSI-ID Setup Switch
1st Unit	1	ON 
2nd Unit	2	ON 
3rd Unit	3	ON 
4th Unit	4	ON 
5th Unit	5	ON 

- The connection diagram shown below is an example for reference.

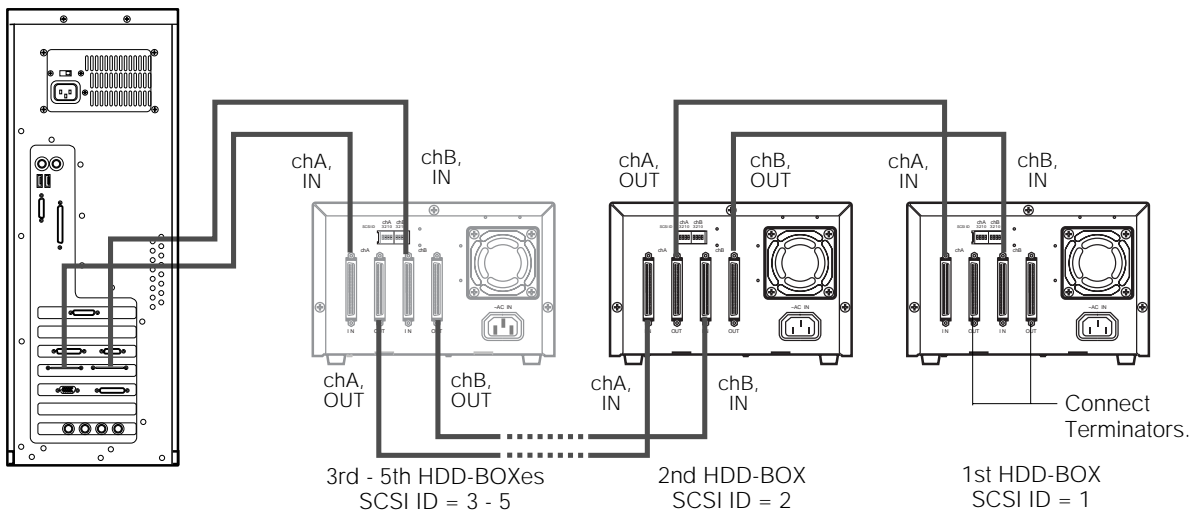

## SPECIFICATIONS

Power Supply :	120V AC 60Hz
Power Consumption :	89W
WIDE SCSI Input :	x2
WIDE SCSI Output :	x2 (Loop through output)
HDD dimensions :	3.5" (102 (W) x 152 (D) x MAX. 42 (H) mm)
Installable HDD Units :	max. 2
Connectable HDD-BOXes :	max. 5
Ambient Operating Temperature :	32°F - 95°F (0°C - +35°C)
Ambient Operating Humidity :	10% - 90%
Dimensions :	210 (W) x 132 (H) x 310 (D) mm 8-1/4"(W) x 5-3/16"(H) x 12-3/16"(D)
Weights :	Min. 5.4 kg (11.9 lbs.) without HDD Max. 7.5 kg (16.6 lbs.) with HDD's

Weight and dimensions are approximate.  
Specifications are subject to change without notice

## STANDARD ACCESSORIES

Power Cord .....	1 pc.
HDD Mounting Angle .....	2 pcs.
HDD Fixing Screw .....	8 pcs.
Mounting Angle Fixing Screw .....	4 pcs.
Mounting Screw for HDD Fixing Angle .....	3 pcs.
Fixing Angle .....	1 pc.

# Panasonic

**Broadcast & Television Systems Company**

**Division of Matsushita Electric Corporation of America**

**Executive Office:** One Panasonic Way 3F-5, Secaucus, NJ 07094

**Regional Offices:**

**EASTERN ZONE:** 43 Hartz Way, Secaucus, NJ 07094 (201) 348-7620

**CENTRAL ZONE:** 1707 North Randall Road, Elgin, IL 60123 (708) 468-5200

**SOUTHERN ZONE:**

**Dallas Region:** 4500 Amon Carter Blvd, Fort Worth, TX 76155 (817) 685-1117

**Atlanta Region:** 1225 Northbrook Parkway, Suite 1-160, Suwanee, GA 30174

Panazip 11 (404) 338-6841, fax (404) 338-6741

**Law Enforcement Video Products:** 1225 Northbrook Parkway, Suite 1-160, Suwanee, GA 30174, Panazip 11 (404) 338-6844, fax (404) 338-6721

**WESTERN ZONE:**

**Seattle Region:** 1200 Westlake Ave., North, Suite 508, Seattle, WA 98109 (206) 285-8883

**Los Angeles Region:** 6550 Katella Ave. 17A-1, Cypress, CA 90630 (714) 373-7271

**Government Marketing Department:** 52 West Gude Drive, Rockville, MD 20850 (301) 738-3840

**MATSUSHITA ELECTRIC OF CANADA LIMITED**

5770 Ambler Drive, Mississauga, Ontario, L4W 2T3 Canada (905) 624-5010

**PANASONIC SALES COMPANY**

**DIVISION OF MATSUSHITA ELECTRIC OF PUERTO RICO, INC.**

San Gabriel Industrial Park, 65th Infantry Ave. KM. 9.5 Carolina, Puerto Rico 00630 (809) 750-4300